

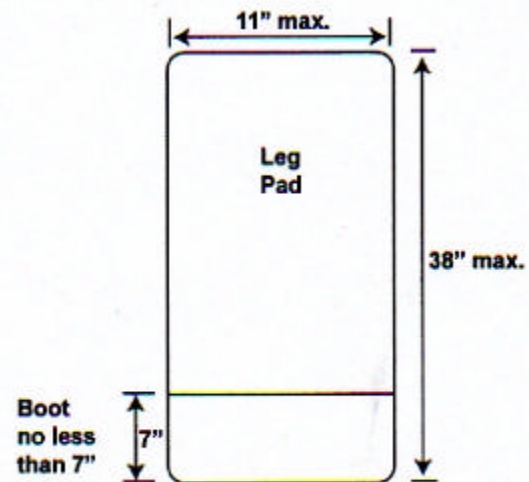

As we approach the start of the 2008-09 season, I want to put together a reference for all of the teams, officials, and fans, outlining the new equipment measurements that **all** goaltenders in the ACHA must adhere to. Keep in mind that these equipment specs were approved by the NCAA in 2006 and have been approved by the ACHA at the National Meeting this spring in Naples, FL. In summary **all** goaltenders **must** have equipment that meets the new size requirements. There is no “grandfathering” of old equipment because a player is in his/her last season, or for any other reason. Below is a summary of the new equipment sizes for goaltenders.

## Leg Pads

The goalkeeper's leg pads shall not exceed 11 inches in width. The maximum length from the bottom mid-point to top mid-point of the pad is not to exceed 38 inches. The boot of the goal pad is to be no less than 7 inches in length. The boot channel of the goal pad must be flat or concave in appearance.



## Blocker

The goalkeeper's blocker glove shall not exceed 8 inches in width or more than 15 inches in length at any point. The flap protecting the thumb and wrist must be fastened to the blocker and this protection must follow the contour of the thumb and wrist. This protective piece shall not exceed seven inches in length when measured from the top of the blocking surface. Raised ridges are not to be added to any portion of the blocking glove.

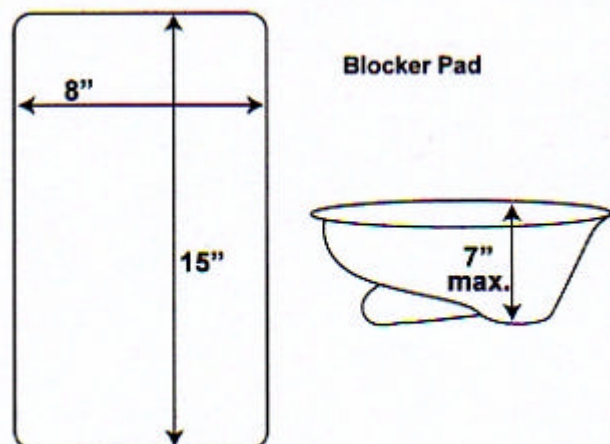

## Catching Glove

The goalkeeper's catching glove may be a maximum of 45 inches measured around the perimeter of the glove. The wrist cuff of the goalkeeper's catching glove shall not exceed 4 inches in width and 8 inches in height. The maximum distance from the heel of the catching glove to the outside edge of the glove shall not exceed 18 inches. Any bar or attachment (cheater bar) between the cuff and the thumb only shall extend from the cuff to the thumb in a straight line.

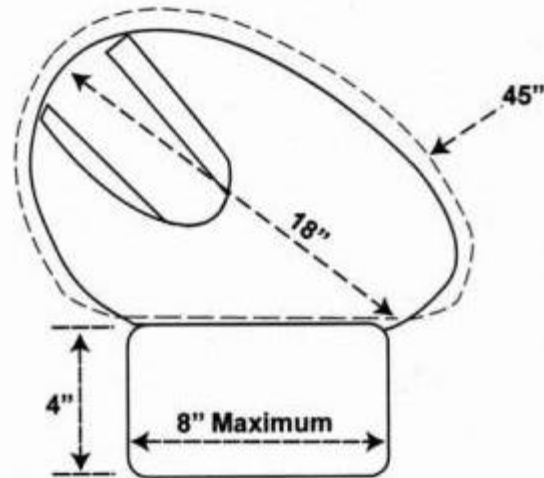

The measurements are straight forward and goaltenders that do not have the required equipment will be penalized and removed from the game. The new equipment sizes are identical to the NHL sizes. There is no problem finding legal equipment in any Pro Shop or on-line equipment store.

The question has also been raised as to whether or not thigh boards are legal in the ACHA. The current NCAA rules do not have a provision for the thigh board, but most of the NCAA leagues made them illegal last season. In addition, they are not legal in the NHL. The new NCAA rulebook will most likely have a provision in the rules making the thigh board illegal. If that is the case, they will be illegal in the ACHA as well. There is no issue however, because the thigh boards are easily removed.

Finally, the "Cat Eye" Goalie mask should be revisited. It is the responsibility of the goaltenders to wear HECC approved face masks. If there is ever a question, all HECC approved equipment has an approval sticker on it. The Goaltenders are NOT to remove the stickers. The Goaltenders must carry the burden of making sure that their equipment is in compliance. There are, however, masks that are the cat-eye style, but meet the HECC standard. These masks have an extra bar on the eye area that closes the gap to the approved opening. Here are examples of both legal and illegal cat-eye masks.

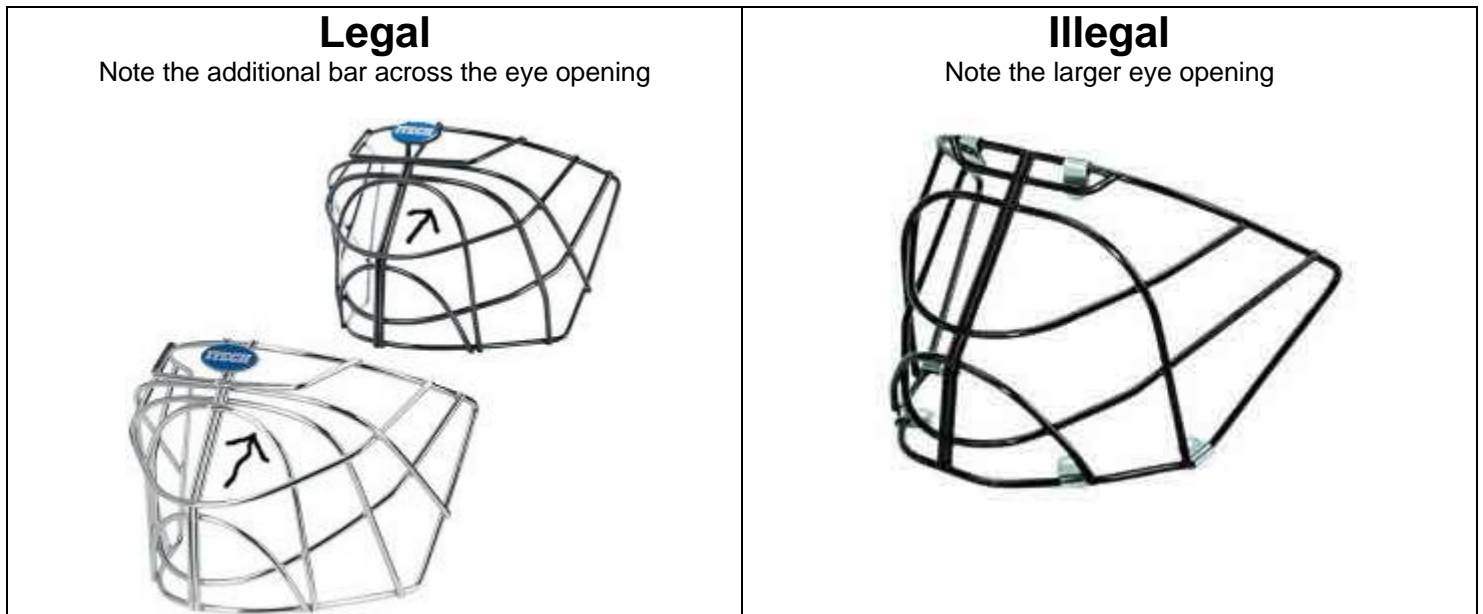

In the end it is up to the teams to make sure that the goaltenders are wearing the proper equipment. Your equipment supplier can help you make sure that you equipment is legal. Now is the time to prepare. Once the season starts, it is too late. If you have any questions please contact your Divisional Commissioner or contact me directly. Enjoy the summer!